

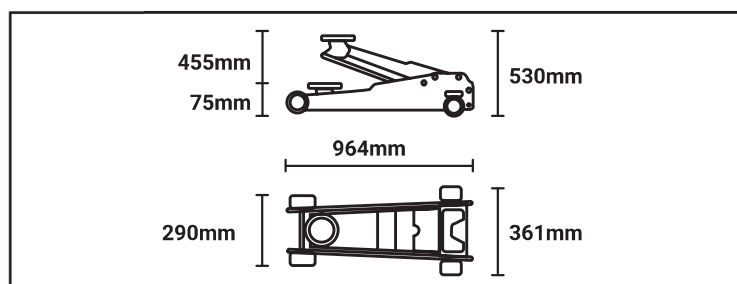

Martinetto idraulico basso profilo 2 t

Caratteristiche:

Altezza minima: 75 mm,
 altezza massima: 530 mm.
 Diametro esterno ruote posteriori: 63 mm, anteriore: 60 mm

REF

4813



2T



42,2kg



1x

 Carrello martinetto 3 t

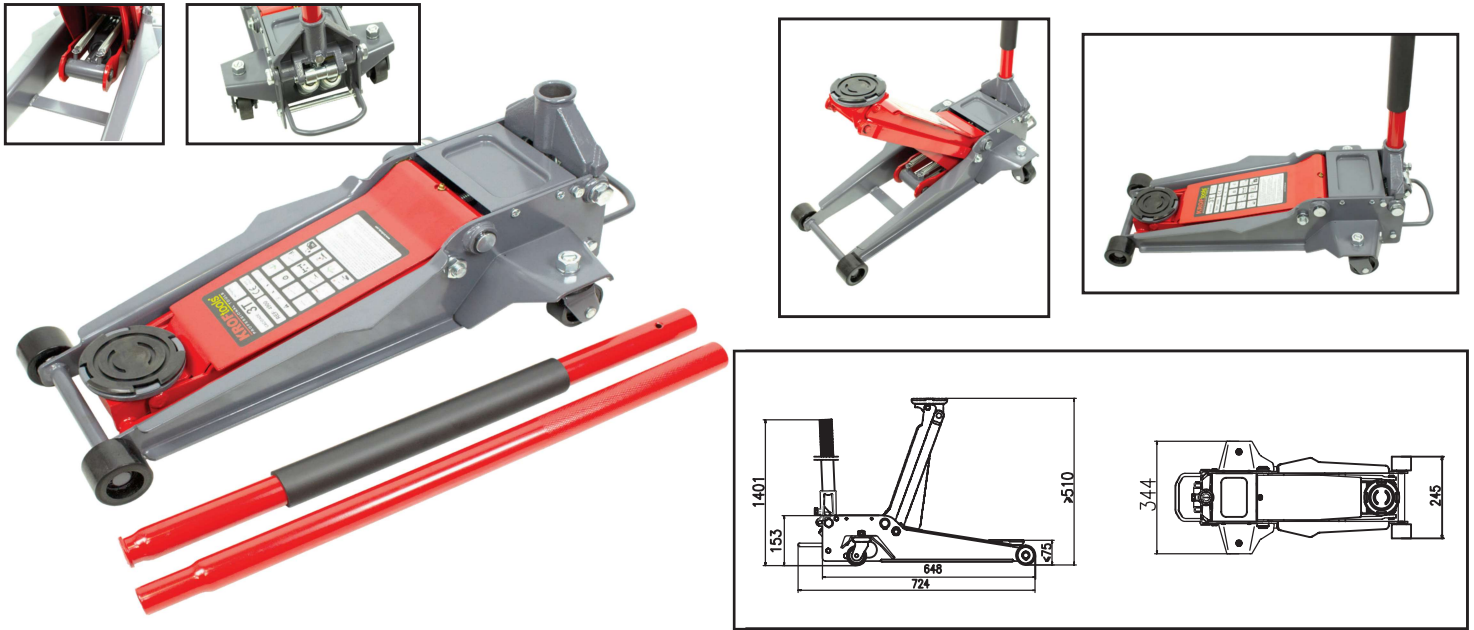

 Caratteristiche:

Altezza minima: 75 mm.
Altezza massima: 510 mm

REF			
4900	3T	30,5kg	1x

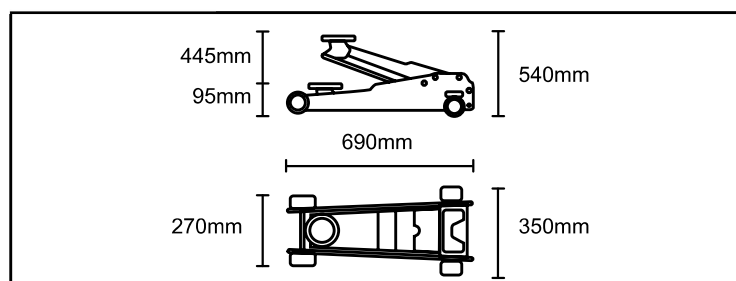
 Martinetto da garage profilo basso 3,5t

 **Caratteristiche:**

Capacità: 3,5 t
 Altezza minima: 95 mm
 Altezza massima: 540 mm
 Peso lordo: 39,5 kg

Dimensioni: 690x350x95 mm
 Lunghezza impugnatura: 1247 mm

REF

4935



3,5T



44kg



1x

Martinetto su trolley 5T

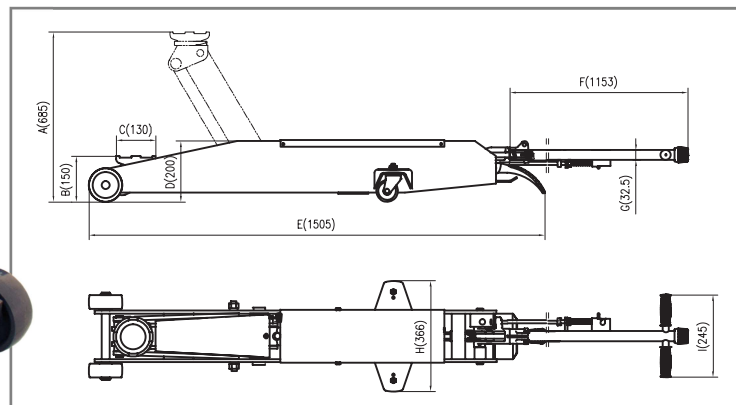

Caratteristiche:

Altezza minima: 150 mm
Altezza massima: 685 mm

REF			
4906	5T	89kg	1x

Martinetto da pavimento 10 t

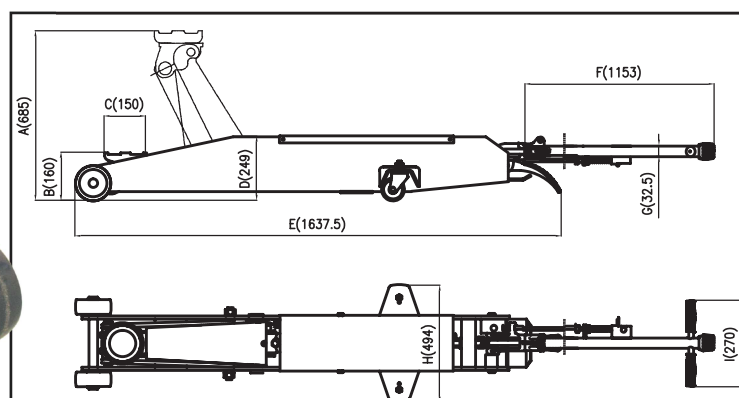
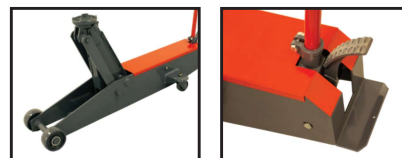

Caratteristiche:

Altezza minima: 160 mm
Altezza massima: 685 mm

REF			
4907	10T	133kg	1x

Martinetto pneumatico idraulico 15-30 t (corto)

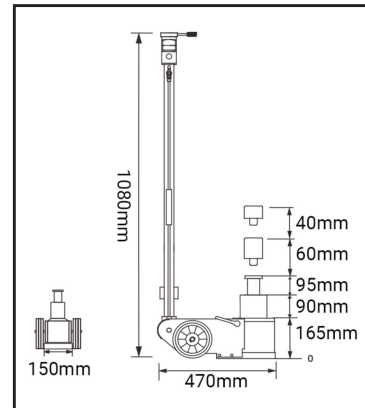

Caratteristiche:

Capacità: 15/30 T
Pressione dell'aria: 0,8-1,2 Mpa
Intervallo di sollevamento: 165-340 mm

Inserti: 40/60 mm
Diametro cilindri: 120 mm

4822

15-30T

32,5kg

1x

Martinetto pneumatico idraulico 20-40 t

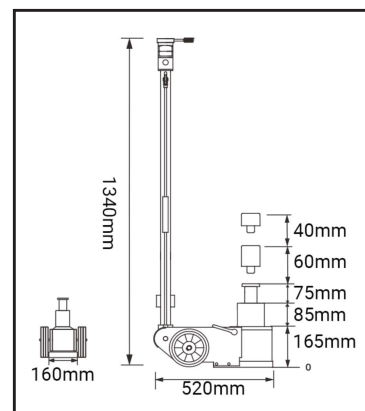

Caratteristiche:

Caratteristiche:
Capacità: 25/50 T
Pressione dell'aria: 0,8-1,2 Mpa
Intervallo di sollevamento: 165-330 mm

Inserti: 40/60 mm
Diametro cilindro: 136 mm

4823

25-50T

38,5kg

1x

Blocco martinetto per modello tesla X/S/3



Caratteristiche:

Dimensione 75x50 mm
Inserire l'utensile nel foro del martinetto
Impedisce il danneggiamento della batteria e del cordolo laterale
Applicazione: Indicato per i modelli Tesla X / S / 3

REF		
4915	149gr	50x

Martinetto pneumatico idraulico 15-30 t (corto)

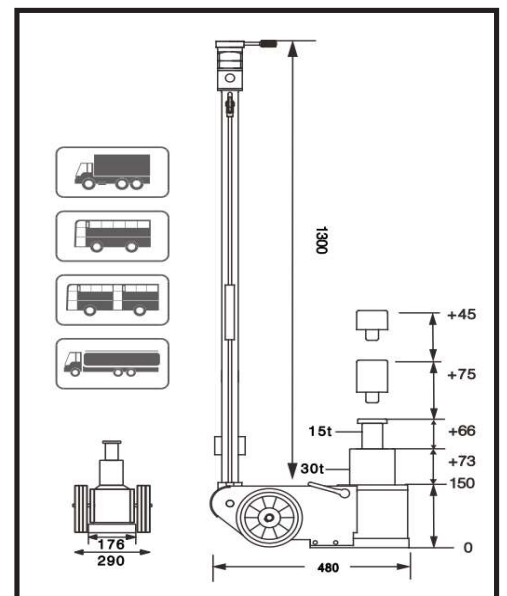

Caratteristiche:

Altezza minima: 150 mm,
Altezza massima: 409 mm
Pressione di esercizio: 0.9-1.2 MPa.
Capacità olio: 0,9 l

REF		
4816	15-30T	34kg
		2x

Martinetto pneumatico idraulico 20-40 t (corto)

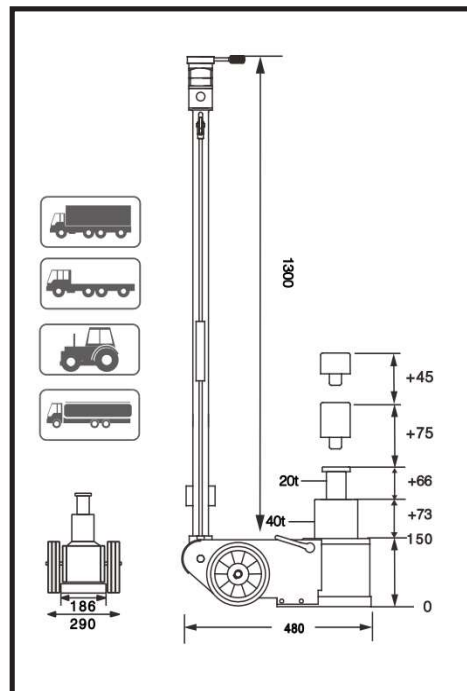

Caratteristiche:

Altezza minima: 150 mm,
Altezza massima: 409 mm
Pressione di esercizio: 0,9-1,2mpa.
Capacità olio: 1L

4817

20-40T

36kg

2x

Martinetto pneumatico idraulico 20-40 t

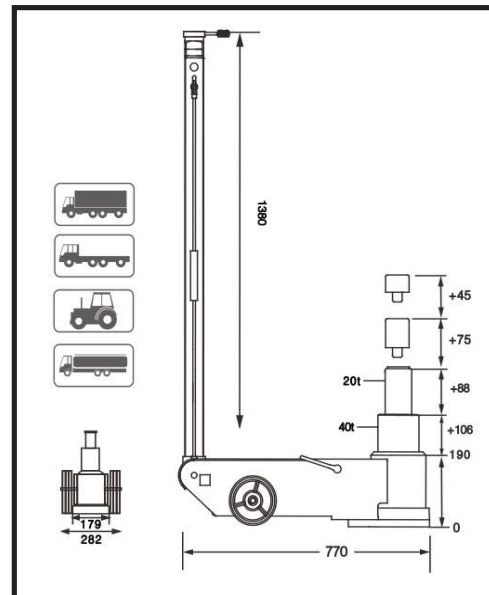

Caratteristiche:

Altezza minima: 190 mm,
Altezza massima: 504 mm
Pressione di esercizio: 0,9-1,2mpa.
Capacità olio: 2.8L

4818

20-40T

58,7kg

2x

Martinetto pneumatico idraulico 10-20-40T

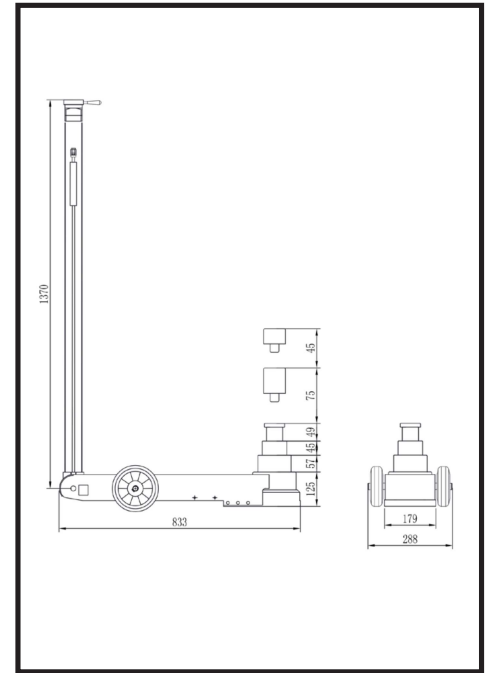

Caratteristiche:

Pressione di lavoro: 0,9-1,2Mpa
Altezza minima: 125 mm
Altezza massima di lavoro: 396 mm
Altezza 40T: 57 mm

Altezza 20T: 45 mm
Altezza 10T: 49 mm
Estensioni: 75 mm e 45 mm

REF			
4812	10-20-40T	45kg	2x

Martinetto pneumatico idraulico 50-80T

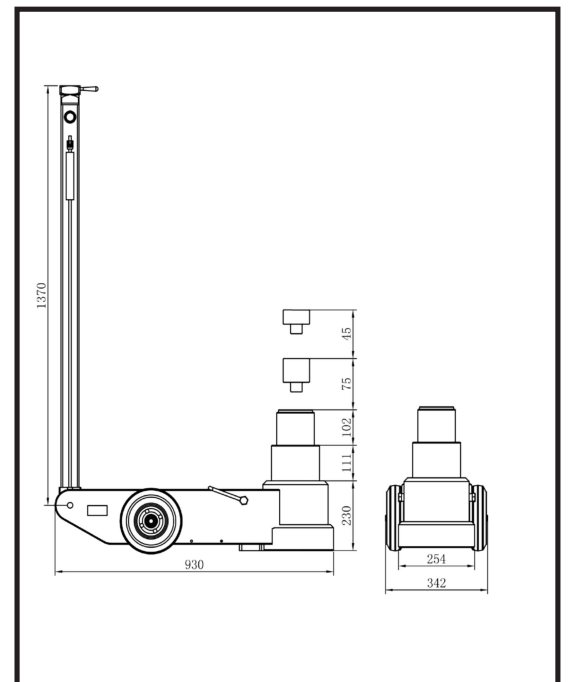

Caratteristiche:

Altezza minima: 230 mm,
Altezza massima: 563 mm
Pressione di esercizio: 0,9-1,2mpa.
Capacità olio: 6.20L

4819

50-80T



114kg

2x

 Prolunghe per martinetto pneumatico idraulico

 Caratteristiche:

Diametro: 30 mm

REF			
481603	45mm	300gr	1x
481604	75mm	450gr	1x

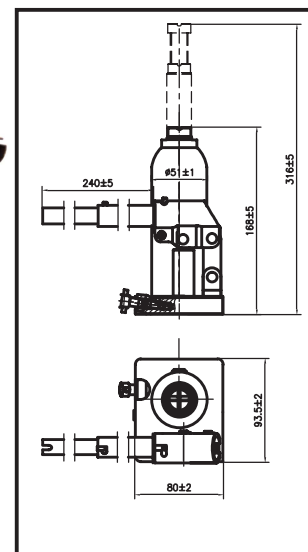
 Martinetto a bottiglia 2 t

 Caratteristiche:

Altezza min.: 168mm
Altezza mas.: 316mm

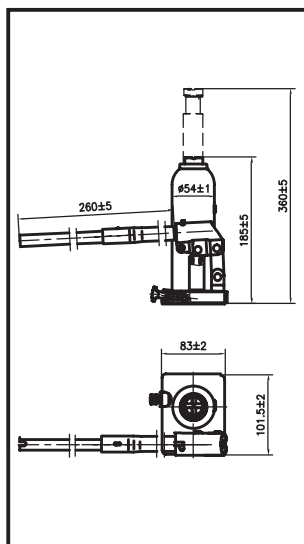
REF			
4702	2T	2,4kg	6x

 Martinetto a bottiglia 3 t

 Caratteristiche:

Altezza min.: 185 mm
Altezza mas.: 360 mm

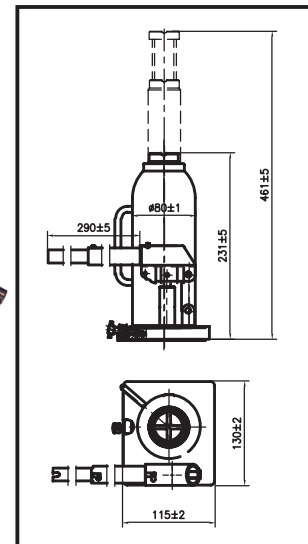
REF			
4703	3T	3,1kg	6x

 Martinetto a bottiglia 10 t

 Caratteristiche:

Altezza min.: 231mm
Altezza mas.: 461mm

REF			
4710	10T	5,9kg	4x

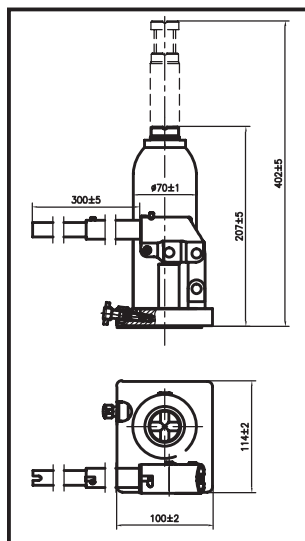
Martinetto a bottiglia 5 t



Caratteristiche:

Altezza min.: 207mm,
Altezza mas.: 402mm

REF			
4705	5T	4,1kg	4x

Martinetto a bottiglia 12 t

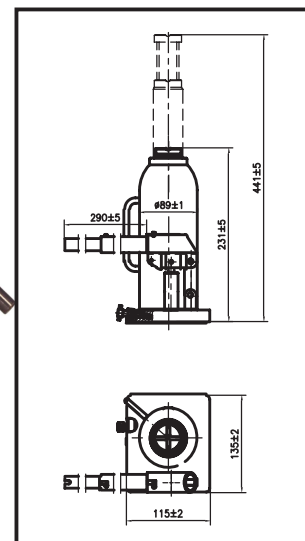

Caratteristiche:

Altezza min.: 231mm
Altezza mas.: 441mm

REF			
4712	12T	6,4kg	1x

Martinetto a bottiglia 16 t

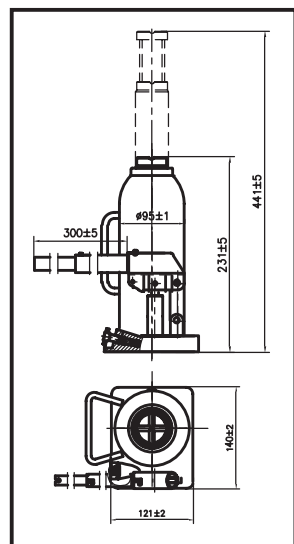

Caratteristiche:

Altezza min.: 231mm
Altezza mas.: 445mm

REF			
4716	16T	7,4kg	2x

Martinetto a bottiglia 20 t

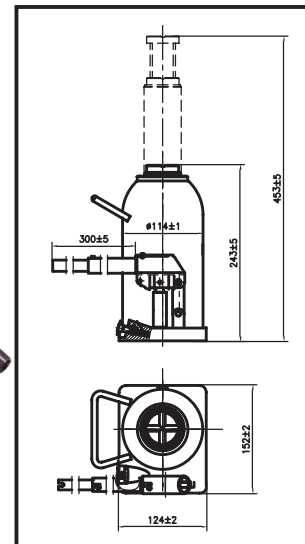

Caratteristiche:

Altezza min.: 243mm
Altezza mas.: 453mm

REF			
4720	20T	9,2kg	2x

Martinetto a bottiglia 30 t

 Martinetto a bottiglia 50 t

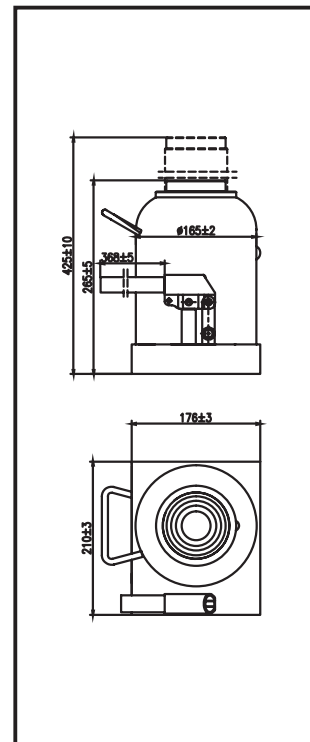
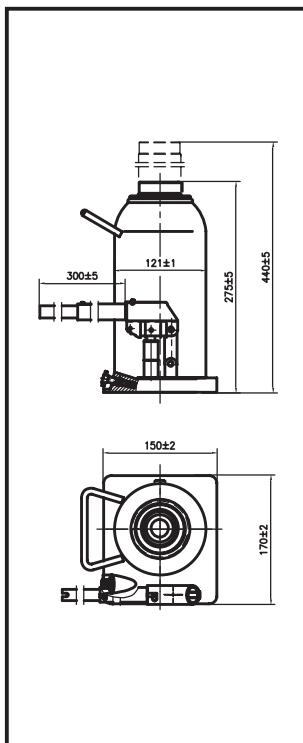

Caratteristiche:

Altezza min.: 275 mm
Altezza mas.: 440 mm

 **Caratteristiche:**

Altezza min.: 265 mm
Altezza mas.: 425 mm

4730

30T

12,9kg

2x

REF



4750

50T

25,9kg

1x

 Martinetto a innesto 135 kg

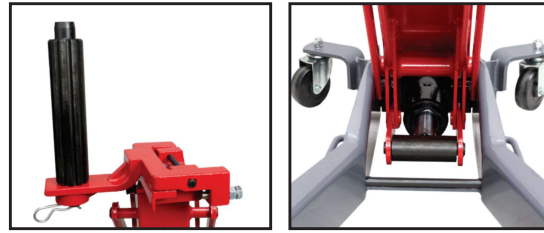

 **Caratteristiche:**

Altezza bassa: 288 mm
Mas. Altezza: 980 mm

REF

4920



135KG



60kg



1x

 Martinetto a trasmissione da pavimento 1 t

 Caratteristiche:

Altezza minima: 175 mm
 Altezza massima: 895 mm

REF

4925



1T



130kg



1x

 Carrello di sollevamento per veicoli pesanti 1200 kg

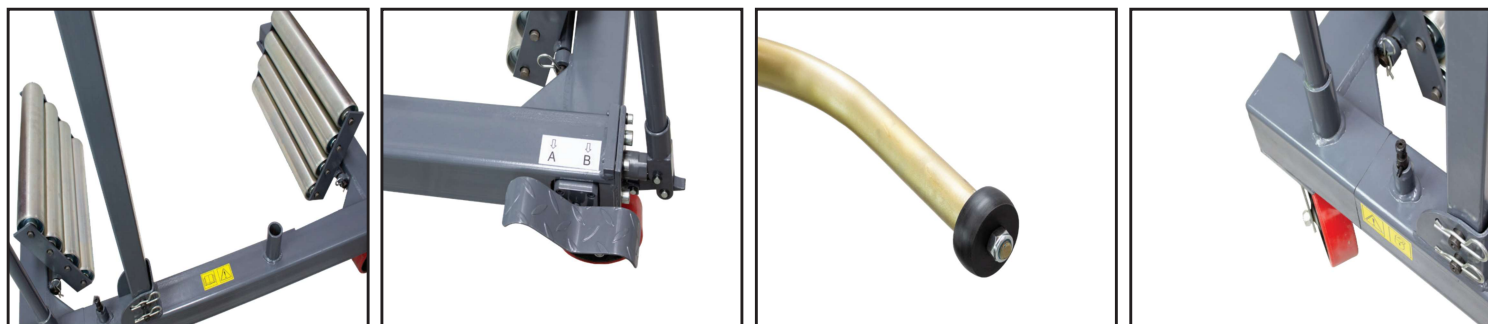

 Caratteristiche:

- Capacità massima: 1200Kg
- Dimensioni: 1310x980x1270 mm
- Diametro ruota min.: 1000 mm
- Diametro ruota mas.: 2200 mm
- Larghezza ruota massima: 800 mm

REF
4930

540kg

131kg

1x

Martinetto a trasmissione 1 t 940-1940 mm

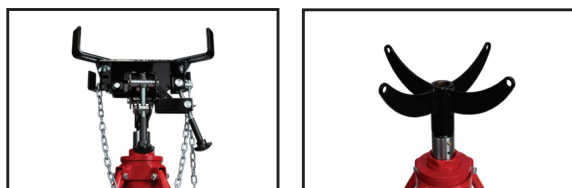
**Caratteristiche:**

Altezza minima: 940mm
 Altezza massima : 1940mm
 Corsa:
 1° stadio 490 mm
 2° stadio 510 mm

4845

1T

74,5kg

1x

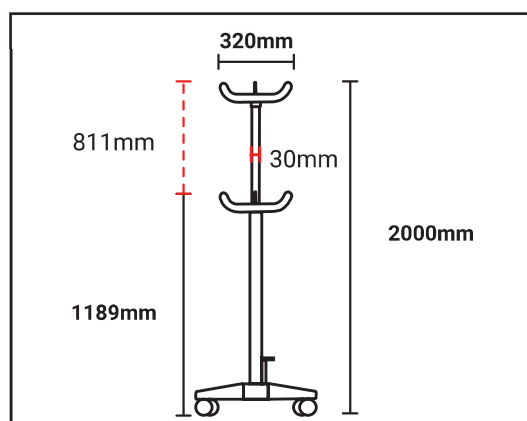
 Martinetto trasmissione 500 kg

 **Caratteristiche:**

Altezza minima: 1189 mm.
 Altezza massima: 2000 mm
 Corsa: 811 mm.
 Pompa doppia we valvola di sicurezza

REF



4825

500kg

28kg

1x

Adattatori per martinetto a trasmissione 500 kg (REF 4825)



REF	⊕	📏	📄
4820A23	23mm	50gr	1x
4820A24	24mm	50gr	1x
4820A25	25mm	50gr	1x
4820A28	28mm	50gr	1x
4820A30	30mm	50gr	1x

Adattatore (REF 4825)



REF	⊕	📏	📄
4820B30	30mm	400gr	1x
4820B33	33mm	400gr	1x

Adattatore trasmissione (REF 4825)



REF	📏	📄
4821	9kg	1x

Supporto puntone per martinetti trasmissione (REF 4825)



REF	📏	📄
4826	2,8kg	8x